

Ultimate Pulling Force



- Perfect maneuvering capability
- Maximum pulling force in its class
- Hydraulic steering both in front and rear axles
- High comfort in operator cabin
- High efficient heater
- Closed brake circuit
- Perfect suspension system
- High loading capacity at rear
- Soft-shift modulation (inching)
- No-spin or limited slip differential
- 4x4 steering
- Tumosan engine (according to the requirement)
- Dana (clark) drive line system



PANTERA



ERSENCER

ENGINEERING Ind. and Co. Ltd.

TOW TRACTOR

TT - 82 / 40

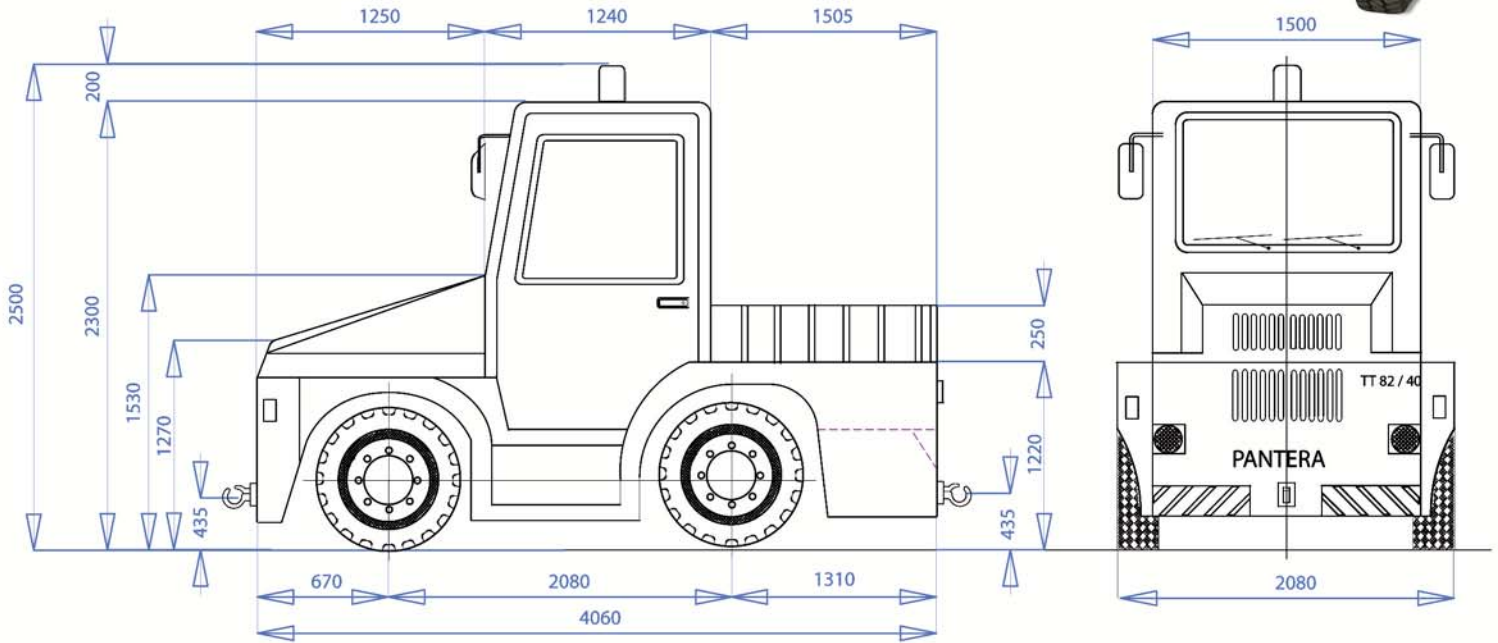

| DIMENSIONS | (MM) |
|----------------|------|
| Overall Length | 4060 |
| Wheel Base | 2080 |
| Overall Width | 2080 |
| Overall Height | 2500 |
| Track | 2030 |
| Turning Radius | 5500 |

| ENGINE | |
|--------------|------------------|
| Make | Tumosan - Diesel |
| Type | 4D39T |
| Displacement | 3908 cc |
| Power | 82Hp / 2500 rpm |

| WEIGHTS | (KG) |
|----------------------|----------|
| Gross Vehicle Weight | 5500 |
| Front Axle | 2900 |
| Rear Axle | 2900 |
| Max Speed | 28 km/hr |
| Drive | 4x4 |

| TRANSMISSION | |
|--------------|---------------------|
| Make | Dana - Spicer |
| Type | Powershift |
| Control | EGS |
| Gear | 4 Forward 3 Reverse |

| STEERING |
|-------------------------|
| Hydraulic |
| Front and Rear Steering |

| BRAKES |
|---------------------------|
| Dual Circuit Closed Discs |
| Mechanical Parking Brakes |

| AXLES |
|-------------------|
| Dana Limited Slip |

| BATTERY |
|---------|
| 90 A |

| TYRES |
|-----------------|
| 8,5 x 17,5 LC/T |

| SUSPENSION |
|-------------------------------|
| Leaf Spring - Shock Absorbers |

| ELECTRIC |
|----------|
| 12 V |

| FUEL TANK |
|-----------|
| 90 Ltr |



ERSENCER ENGINEERING IND. AND CO. LTD.